

WELCOME TO YOUR HOLIDAY PROPERTY

This folder provides information on your holiday property and handy hints and tips to help you make the most of your stay.

We recommend that you have a look at the folder at the start of your holiday.

You will have full use of the cottage/apartment from 16:00 (4pm) on the day of your arrival until 12:00 noon on your day of departure, unless otherwise specified in your booking confirmation.

If you identify any faults with the property or it is not sufficiently clean, please let your Property Manager know immediately. Their contact details can be found below and/or in the booking confirmation sent to you. Unfortunately, we are not able to accept responsibility for any complaints made after the conclusion of your stay.

THE FOLDER CONTAINS A WEALTH OF USEFUL INFORMATION, INCLUDING:

- Cleaning instructions: please look through this section even if cleaning is included in the cost of your stay or you have booked it as an additional service.
- General information for guests
- Instructions on how to use the sauna and fireplace
- Instructions on how to use the gas cooker
- Safety instructions
- Hints and tips from the owner
- Everyman's rights: the Finnish outdoor access code
- Lomarengas booking terms and conditions

SITE MANAGER RESPONSIBLE FOR YOUR HOLIDAY PROPERTY:

Name _____

Telephone number _____

**EMERGENCY
TELEPHONE
NUMBER**

112

ENJOY YOUR STAY!

Lomarengas

50 years of cottage holidays in Finland.

CLEANING INSTRUCTIONS

Please note that the cost of your stay does not include a final clean unless otherwise specified or agreed.

WHEN YOU ARE MAKING A FINAL CLEAN AT THE END OF YOUR STAY, PLEASE MAKE SURE THAT YOU ADHERE TO THESE MINIMUM REQUIREMENTS:

- Air all bedding outside
- Hoover all floors and rugs and wipe floors clean using a damp mop
- Wash up all dishes and return them to where you found them
- Clean the draining board, hob, oven, fridge, microwave and all tables and countertops
- Clean all toilets and sinks
- Clean the sauna and shower room
- Take all rubbish to the bin area
- Leave all bottles and cans in a plastic bag by the front door or bring them with you

Please ensure that if your property has an outdoor space, barbeque or barbeque hut, these are left neat and tidy.

To make sure that you can make the most of every single moment of your holiday, book a final clean through your Property Manager at least 24hrs prior to your departure.

PROPERTY MANAGER:

Name

Telephone number

If you are accompanied by a pet during your holiday at one of our properties that welcomes pets, please ensure that you clear up any hairs from the property and pick up any droppings from outside areas.

IF YOUR RENTAL INCLUDES A FINAL CLEAN OR YOU HAVE REQUESTED IT AS AN ADDITIONAL SERVICE, PLEASE BEAR IN MIND THAT YOU ARE STILL REQUIRED TO ATTEND TO THE FOLLOWING:

- Wash up all dishes and return them to where you found them
- Take all rubbish to the bins
- Leave all bottles and cans in a plastic bag by the front door or take them with you
- If you have booked bed linen as an additional service or bed linen is included in the cost of your stay, please strip all beds and leave bed linen and towels on the beds.
- Take all your food with you or place it in the bin.

GENERAL INFORMATION FOR GUESTS

1. The standard temperature at your property is approximately 20–22°C. Please bear in mind when adjusting the underfloor heating that it will take at least 12 hours to achieve the desired temperature. **Do not place clothes or other items on the electric radiators to dry, as this constitutes a fire hazard.**
2. There is a limited amount of hot water available at the property, try to conserve it wherever you can. In the majority of our properties, water is heated during the night.
3. When the electric sauna is on, some of the heating may become automatically switched off -> please ensure that you switch off the sauna as soon as you are finished and bear in mind that it may not be possible to run all electrical appliances in the property at the same time. Do not place aromatherapy or other scented oils on the sauna stove. **Do not place clothes to dry in the sauna, as this constitutes a fire hazard.**
4. Please note that only detergent designed for dishwashers should be used in the dishwasher, do not use washing-up liquid. All dishes must be rinsed before they are placed in the dishwasher. Do not open the dishwasher door while the machine is running. Remember to turn on the dishwasher water supply before switching it on.
5. Remember to turn on the washing machine water supply before switching it on.
6. Candles and outdoor candles must be placed on a fireproof base. You need to empty and clean the barbecue after use. Please make sure you observe fire safety measures at all times.
7. Smoking is strictly forbidden in all indoor areas.
8. Please remember to close all windows and doors after airing the property.
9. If you have moved any pieces of furniture, please return them to their original position.
10. For lake and seaside properties: please pull rowing boats onto dry land. Alternatively, ensure that they are safely secured. Place oars inside the boat. Bring all life vests indoors. We recommend that life vests are worn at all times when boating.
11. Please contact your Property Manager in the event of any breakages during your stay. Compensation should be agreed with the property owner prior to your departure.
12. Please note that bed linen, towels and cleaning are not included in the cost of your stay unless otherwise agreed and specified in your booking confirmation. All guests are required to use bed linen. Please contact your Property Manager if you need to hire bed linen.

Switch off all lights, close windows and lock doors when you leave. Please return all heating and air conditioning settings to how you found them (i.e. do not switch off the heating during winter months as this could lead to frost damage to the property).

Do not hesitate to contact your Property Manager if you require any additional information regarding your property. If any appliances are broken due to inappropriate use, we will expect you to cover the cost of a replacement. Always ask if you are not sure how to correctly use an appliance or other equipment.

SWITCHING ON THE ELECTRIC SAUNA

Before switching on the sauna, always check the sauna facilities. Please ensure that there are no items of clothing left on the sauna stove and that both the door and window are shut.

HEATING THE STOVE

The sauna stove is controlled with a timer:

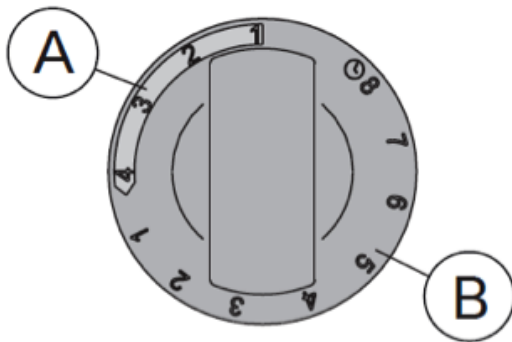

At 0

the stove is switched off and will not heat up

1–4 hours (A)

the elements will switch on, the stove will heat up and remain warm for the selected number of hours (h).

1–8 hours (B)

timer setting, the stove will switch on after the selected number of hours. For example: if you choose setting 4, the stove will switch on after four hours and remain warm for four hours unless it is switched off manually.

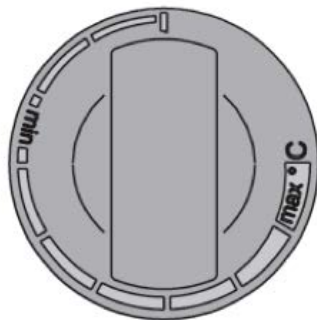

To adjust the temperature, use the thermostat dial. The best way to find the right temperature for you is through trial and error. We recommend that you start with the highest setting. If you find that this is too hot for you, turn the dial counterclockwise. Please note that even a small adjustment can cause a significant change in the sauna temperature level. As a rule, saunas are at their most enjoyable at around 65–80°C.

As the sauna heats up, heating elsewhere in the property may become switched off. **Please ensure that you switch off the sauna stove as soon as you have finished** to ensure that heating is switched back on elsewhere in the property.

“LÖYLYNHEITTO” – ADDING WATER TO THE STOVE

As the sauna heats up, the air becomes drier. As a result, you will need to increase the humidity by throwing water on the rocks while you are bathing. You will be able to find the right temperature and humidity level through trial and error.

Please note that you must not throw anything other than water onto the rocks.

SWITCHING OFF THE SAUNA STOVE

Turn the timer dial counterclockwise to the 0 position.

HEATING UP A WOOD-BURNING SAUNA

Before switching on the sauna, always check the sauna facilities. Please ensure that there are no items of clothing left on the sauna stove and that both the door and window are shut.

HEATING THE STOVE

1. If the stove is fitted with a water heater, fill it up. As the name suggests, the water heater is designed to heat up water for washing and bathing purposes, please do not place detergent in it.
2. Make sure that the damper(s) are open
3. Open up any air vents
4. Place a selection of clean and dry kindling and wood in the firebox.
5. Now add your tinder. This could take the form of a handful of twigs or some bark or newspaper. Place it on top and underneath the wood.
6. Once the kindling is in place, light the fire.
7. After the fire has started to burn, you can close the air vents, if possible.
8. Add more wood to the stove during the heating process and while you are bathing to keep the sauna and the rocks at the required temperature.
9. As a rule, saunas are at their most enjoyable at around 65–80°C.

“LÖYLYNHEITTO” – ADDING WATER TO THE STOVE

As the sauna heats up, the air becomes drier. As a result, you will need to increase the humidity by throwing water on the rocks while you are bathing. You will be able to find the right temperature and humidity level through trial and error. Please note that you must not throw anything other than water onto the rocks.

Please contact your Property Manager if you have any questions relating to the heating process.

MAKING A FIRE IN THE FIREPLACE

1. If the cooker extractor fan is on, switch it off.
2. Open the damper(s)
3. Open up any air vents
4. Place a selection of clean and dry kindling and smaller pieces of wood in the firebox.
5. Now add your tinder. This could take the form of a handful of twigs or some bark or newspaper. Place it on top and underneath the wood.
6. Once the kindling is in place, light the fire.
7. Once the fire is established, you can close the air vents, if possible.
8. When you need to add more wood to the fire, you can start using larger logs.
9. It is extremely important that you do not shut the damper(s) before the embers have burned out.

We ask that you do not chop wood in front of the fireplace/woodburner, please do this in the woodshed or similar using the facilities provided. Chopping wood in the area in front of the fire could damage the floor surface.

Please contact your Property Manager if you have any questions relating to the heating process.

THE GAS COOKER – INSTRUCTIONS FOR USE

LIGHTING THE GAS COOKER.

1. Open the gas cylinder vent.
2. Press down the switch on the gas cooker and turn it to the left (continue to hold it down as you are turning it).
3. Light the flame.
4. Continue to hold the switch down for approximately 15 seconds to allow the gas safety element to heat up.
5. When you have finished cooking, switch off and clean the cooker.

Turn off the gas cylinder for the night and as you leave.

SAFETY INSTRUCTIONS

IMPORTANT INFORMATION FOR YOUR PROPERTY

Address

Map coordinates

Property Manager

**EMERGENCY
TELEPHONE NUMBER 112**

Please familiarise yourself with the contents of this folder and make sure you are aware of the following.

- The location of the fire alarms
- The location of the fire safety equipment
- The location of fire exits
- User instructions for all appliances

IF YOU NEED TO MAKE AN EMERGENCY CALL

State who is calling:

- Give the operator your name and telephone number

Explain what has happened:

- Accident, fire, water damage or other hazardous situation
- Any other hazards?

Give details of your exact location:

- Local authority area and street address
- Provide map coordinates if required
- Directions

Respond to any questions the emergency operator may have:

- Do not hang up the call until you have been given permission to do so

Always dial 112:

- If there is an immediate danger to life or property

FIRE

If a fire alarm goes off or you detect smoke:

- Identify the site of the fire, if possible
- Assess the situation and draw up a plan of action
- Divide tasks between everyone present

Rescue:

- Those in immediate danger

Extinguish a fire:

- Using a fire blanket or hand-held fire extinguisher
- Using water (do not touch electrical appliances if you have used water to fight the fire)

Call 112, the emergency telephone number:

- You must notify the emergency services of all fires, including those you have managed to put out yourself

Prevent the fire from spreading:

- Close all doors, windows and vents as you are leaving

Exit the property:

- Make sure you have identified all exits, including emergency exits, in advance and make sure you know how to access them

Direct:

- Fire service/ambulance when they arrive

ACCIDENT OR MEDICAL EMERGENCY

Examine the casualty

- Are they breathing? Listen for breathing sounds close to their mouth, use your hand to detect breathing
- Undo any restrictive items of clothing, ensure the casualty is in a well-ventilated area
- Is the casualty able to communicate?
- Are they injured?

Summon assistance

- Call 112, the emergency telephone number:
- Stay with the casualty while you are making the call, let them speak to the operator if possible

Administer first aid, as needed

- Always follow instructions from emergency personnel

Encourage the casualty to stay calm, do not leave them alone

EVERYMAN'S RIGHTS – THE FINNISH OUTDOOR ACCESS CODE

Finnish Everyman's rights are a legal concept under which everyone is entitled to access the outdoors, regardless of ownership.

You do not need the landowner's permission to access land and there is no charge for it. However, you must not cause a disturbance or nuisance to others.

Everyman's rights are an integral part of Finnish culture and enshrined in law. Everyman's rights apply to all nationalities and are not limited to Finnish citizens.

EVERYMAN'S RIGHTS IN BRIEF

You may:

- Walk, run, ski or cycle, except near homes and gardens and any fields, meadows or other agricultural land that could become damaged
- Set up a temporary camp in areas you can access under the code, provided that you keep away from residential buildings
- Pick wild berries, fungi and flowers
- Fish with a rod and line (including ice fishing in winter)
- Boat, swim and bathe in inland waterways and the sea, including accessing the ice in winter

Please ensure that you protect your neighbours' privacy by maintaining a distance of at least 100 metres to the nearest holiday home, garden, beach, sauna or jetty.

You may not:

- Cause a disturbance or damage property
- Disturb or damage birds' nests or hatchlings
- Disturb reindeer or game
- Fell or damage growing trees, collect fallen or desiccated trees, shrubs, lichen, moss or similar from land owned by others
- Light open fires except in an emergency
- Disturb people's privacy by camping too near them or making noise (100 metres)
- Leave litter
- Drive motor vehicles off road without permission from the landowner
- Fish (except with rod and line) or hunt without the appropriate permits
- Disturb tagged fishing nets or other traps

TERMS OF BOOKING:

Lomarengas Oy, Ylläksen Matkailu Oy and Wild Nordic Ltd (hereinafter Lomarengas) apply the following terms and conditions to the leasing of cottages and holiday apartments (hereinafter destination). These terms and conditions become binding to both parties once the client has paid the deposit mentioned in these contract terms to Lomarengas or paid both the deposit and the final instalment together.

The person making the booking must be of legal age when doing so (18 years or older).

The booking can be made online, in which case the booking confirmation will be sent to the client's e-mail address immediately. The client must pay at least the deposit (20% of the rent of the destination) in conjunction with the booking by credit card. An invoice for the remaining amount will be e-mailed to the client on the first weekday following the booking date. The client may also choose to pay the full price of the booking at once, in which case the confirmation with the contact particulars of the owner or custodian of the destination, driving directions to the location where the key will be handed over or to the destination will be sent to the client's e-mail address immediately.

Bookings can also be made at Lomarengas sales offices or through our telephone service, in which case Lomarengas will invoice the client via mail or e-mail after the booking is registered.

Any objections to the invoice must be made within 7 days of the invoice date. The invoice must be settled as a SEPA payment (with IBAN account number and BIC bank code) and using the reference number mentioned in the invoice.

The invoice will include the name and contact particulars of the owner or custodian of the destination, driving directions to the location where the key will be handed over or to the destination.

The booking is confirmed once the customer has paid the deposit (20% of the destination rent) by the due date or once the customer has paid both the deposit and the final instalment together. The final instalment must be paid no later than six (6) weeks prior to the start of the holiday.

In addition to rent, a €20 delivery fee will be charged.

If the booking is made 63 days (9 weeks) or more before the start of the rental period, the rent will be paid in two instalments. The deposit must be paid within 14 days of the invoice date. In the case of Internet bookings, the deposit must be paid immediately on booking. The remaining amount must be paid 6 weeks before the holiday is due to start.

If the booking is made 50–62 days (7–9 weeks) before the start of the rental period, the sum must be paid in full and in one instalment 6 weeks before the holiday is due to start. In the case of Internet bookings, the deposit must be paid immediately on booking and the remaining amount must be paid 6 weeks before the holiday is due to start.

If the booking is made 28–49 days (4–7 weeks) before the start of the rental period, the sum must be paid in full and in one instalment within one week of the invoice date. In the case of Internet bookings, the deposit must be paid immediately on booking and the remaining amount must be paid within one week of the invoice date.

If the booking is made 27 days or less before the start of the rental period, the full sum must be paid immediately on the day of booking. In the case of Internet bookings, the full sum must be paid immediately on booking by credit card or through an online bank.

If the client fails to pay or misses the payment deadline, Lomarengas may cancel the booking without further notification.

NEW YEAR'S BOOKINGS

A destination-specific departure cleaning and bed linen charge will always be added to the price of bookings made for the period 26 Dec–10 Jan. Payment of the final instalment falls due 10 weeks prior to the start of your vacation.

CANCELLATION OR CHANGE OF BOOKING

Any cancellations must be made to Lomarengas in writing by letter to the address Lomarengas Oy, Sörnäisten rantatie 29, FI-00500 Helsinki or by fax to the number +358 306 502 500 or by e-mail to sales@lomarengas.fi. The date on which Lomarengas receives the notification will be regarded as the date of cancellation.

A cancellation made outside of office hours (weekdays 8:30am–5pm, Sat 10am–6pm) will be considered as having been made on the next office day.

Clients who cancel a booking will forfeit their deposit (20% of the price of the destination) and the delivery fee.

If the cancellation is made less than 28 days before the start of or during the stay, payments made by the client will not be refunded.

Regardless of the above, all sums with the exception of the deposit and delivery fee paid to Lomarengas will be refunded if the client or a person from the same household falls seriously ill, has an accident or dies. In this case, Lomarengas must be informed immediately of the cancellation, which must be properly verified by, for example, a doctor's certificate.

If the cancellation is made less than 48 hours from the start of or during the holiday, payments already made by the client will not be refunded.

Lomarengas will charge €20 for any changes to bookings (destination, dates, extra services or number of persons). All changes must be made at least six (6) weeks before the start of the stay. Any changes made after this date will be treated as a cancellation of the previous booking and a subsequent new booking.

Customers are not entitled to a rent refund if they do not occupy the destination or arrive late for their stay. If a customer interrupts their booking and departs the holiday destination before the end of the lease period, no compensation will be paid for the unused time and the customer is not entitled to a rent refund.

RIGHT OF LOMARENGAS TO CANCEL A BOOKING

Lomarengas may cancel a booking in the event of force majeure. In this case, the client is entitled to a full refund of the sum paid to Lomarengas. If a booking has to be interrupted because of disruptive behaviour on the part of the client, no payments will be refunded.

If the customer fails to pay or misses the payment deadline, the booking may be cancelled without separate notification.

SERVICES MENTIONED IN THE DESTINATION DESCRIPTION

The description of the destination mentions the services available nearby (e.g. railway station, bus stop, restaurant, shop, ski lift, etc.) Lomarengas cannot guarantee the availability of general public services, which are not directly associated with the destination, during the stay of the guest and any mentions thereof are non-binding.

STAY AT DESTINATION

Most usually, the destination will be at the client's disposal from 4pm on the day of arrival

to 12 noon on the day of departure. In the case of a weekend stay, some destinations are at the client's disposal to 6pm on Sunday evening. At ski resorts, destinations are most usually at the client's disposal to 12 noon on Sunday in the case of a weekend stay. The destination-specific checkout and key handover time is mentioned in the booking confirmation or the driving directions page appended to the invoice.

The owner or custodian is entitled to charge a security deposit of €150 on arrival to cover possible damages or the non-performance of obligations on the part of the client. The destination's owner/custodian will return the security deposit on the day of departure. Damage repairs and the cost of cleaning may be deducted from the security deposit.

The keys to the destination will be handed over to the client at the time of arrival as estimated and notified to the owner or custodian by phone or in writing. If the client fails to show up at the scheduled time or if no notification of the client's time of arrival is provided, Lomarengas cannot guarantee that the keys will be available for handover.

The rent pays for the right to use the destination during the booked period. Normal energy consumption, furnishings, cooking and eating utensils, mattresses, blankets and pillows are included in the rent.

Firewood is included in the destination rent unless otherwise stated in its description. The amount of firewood available during the stay may be restricted in the case of some destinations. Dish-washing detergents, basic spices as well as kitchen and toilet paper rolls are not included in the rent.

The colour, taste and smell of tap water available in some destinations, especially in the countryside, may be non-optimal.

Free use of a rowing boat is only included in summertime rentals of shore cabins if this is explicitly mentioned in the destination description. A separate charge may be made for the use of a sauna and rowing boat in holiday cottage villages or resorts.

Sheets and towels are not included in the rent unless otherwise stated in the destination description. Guests must use bed linen. At most destinations, sheets and towels can be ordered for a separate fee in conjunction with the booking. The customer should contact the Lomarengas offices in advance to make sure that sheets and towels are available.

The customer is responsible for cleaning the destination during the rental period.

The number of people using the destination must not exceed the number of sleeping places stated in the description or the number agreed on during booking. If you are planning to have a party, where the maximum number of guests is temporarily exceeded, you should agree about that in advance with the owner, custodian or Lomarengas. Tents and caravans or use of rentable equipment such as hot tubs are not permitted at the destination without the permission of the owner or custodian. Smoking is not allowed indoors. Some holiday resort destinations enforce a so-called quiet period at night-time, which clients must comply with.

Pet-owners must notify their intent to bring an animal to the destination when booking; one pet may only be brought to destinations which explicitly allow this. Permission to bring more than one pet must always be sought in advance from the owner or custodian. Some destinations levy an additional fee for pet access.

OBLIGATIONS OF THE CLIENT AND HANDOVER OF THE DESTINATION ON THE DAY OF DEPARTURE

The client will hand over the destination and its keys at 12 noon on the day of departure unless otherwise mentioned on the invoice. If the client intends to leave at some other time, he or she must make arrangements for the handover of the key and the return of the security deposit with the owner or custodian well in advance of departure.

If the client leaves at an unusual time (e.g. at night) or does not provide notification of his or her departure, the owner or custodian is entitled to return the security deposit at a later date.

Clients are liable for any damages they cause to the destination property. The owner or custodian must be notified immediately of any damages caused. The client is required to pay the owner or custodian direct for any damage caused to the destination or its contents during occupancy.

Clients are responsible for cleaning the destination before departure unless the destination description states otherwise. A departure cleaning service can be ordered in conjunction with booking.

Departure cleaning must include the washing and return of dishes to their original place, garbage removed to the waste disposal point, removal of empty bottles and cans, and putting furniture back to its original place. Food should be taken away or to the waste disposal point. Carpets and floors should be vacuum cleaned, the floors wiped with a damp mop, tables and surfaces wiped with a damp rag, bedclothes aired outdoors, the sauna and WC cleaned. The yard area and barbecue location must be left in a tidy condition. The departure cleaning should be performed in its entirety on the day of departure.

A separately ordered departure cleaning service or a departure cleaning service included in the destination rent does not cover dish-washing, returning table and cookware to their original place or garbage removal. Clients must also remove empty bottles and cans from the property and return any moved furniture to their

original place. Any food must be taken away or to the waste disposal point.

Used sheets and towels must be piled on a bed if the client rented bed linen or it was included in the destination rent.

Indoor smoking is prohibited in all destinations. The destination must be tidy on departure. The client is liable to compensate the expenses of cleaning the holiday destination if guests have smoked indoors at the cottage or have failed to clean it appropriately and the owner/custodian of the cottage is forced to carry out these chores before the arrival of the next client.

FORCE MAJEURE

Lomarengas will not be liable for any damage or inconvenience incurred by the client in the event of an unpredictable and insurmountable obstacle (force majeure) or some other comparable reason (such as a power failure, or natural phenomena like algae blooms or the occurrence of animals like mice or insects) that was not caused by Lomarengas and whose effects Lomarengas could not be reasonably expected to prevent. Neither is Lomarengas responsible for any damage or inconvenience caused by regular natural phenomena.

OBJECTIONS AND COMPLAINTS

Any objections and complaints regarding the destination must be made immediately once the cause for them arises and addressed to the owner or custodian of the destination direct. If the matter is not satisfactorily attended to, the client should contact Lomarengas within 72 hours.

Should the matter still not be satisfactorily attended to, the client may make a written complaint to Lomarengas. This must be done within one month of the end of the rental period. If the client and Lomarengas fail to reach an accord on the matter, citizens of EU/EEA countries can turn to the European Consumer Centre either in Finland <http://www.ecc.fi/en/> or their home country http://ec.europa.eu/consumers/solving_consumer_disputes/non-judicial_redress/ecc-net/index_en.htm.

Citizens of other countries can contact the Finnish Consumer Advisory Service <http://www.kkv.fi/en/about-us/online-consumer-services/advice-for-consumers/> (limited advice available in English). A dispute involving citizens of EU/EEA member states as well as other countries can, if necessary, be dealt with by the Finnish Consumer Disputes Board <http://www.kuluttajariita.fi/en/index.html>. (NB: the complaint forms used in the dispute resolution process are only available in Finnish and Swedish. If the client does not immediately report observed deficiencies to the owner or custodian during the rental period, the destination will be considered to have been in the contractually-required condition. It is impossible to jointly verify deficiencies reported after the end of the rental period, and Lomarengas will therefore not be liable to compensate for them in any way.)

If the customer discontinues a booking and departs the destination before the end of the rental period, the unused time will not be reimbursed nor will the customer be entitled to a rent refund.

RIGHT TO CHANGE PRICES

Once an agreement has been made, Lomarengas has the right to raise and a corresponding obligation to reduce the agreed price in the event of any changes in the taxes or public charges affecting the price of the holiday service.

ERRONEOUS PRICE INFORMATION

Lomarengas shall not be bound by an error in the listed price if the price is so clearly erroneous that it is reasonable to expect the customer to notice it. Examples of such cases include a situation where the difference between the listed price and the actual price is substantially large or when the erroneous price can be considered exceptionally low when compared to the general price level.

APPLICABLE LAW AND VENUE FOR THE RESOLUTION OF DISPUTES

The contracting parties will attempt to resolve any disputes out of court. Should they fail to reach agreement, any disputes will be settled by the Helsinki District Court. The contract is governed by Finnish law.

11/2016

ENSURE THE SUCCESS OF YOUR HOLIDAY

HERE'S A LIST OF SOME THINGS THAT YOU SHOULD REMEMBER WHEN DEPARTING FOR A COTTAGE HOLIDAY IN FINLAND.

ARRIVAL TIME NOTIFICATION

Please notify the cottage owner/caretaker of your arrival time and arrange for the key handover at least one day before the start of your reservation unless the driving instructions mention otherwise. This will ensure that the key is available on your arrival. The contact details of the owner/caretaker were sent to you with the invoice. Tip: send a text message as notification of your arrival once you have crossed the border into Finland.

You may go to the cottage no earlier than at 4pm on the first day of your reservation and must leave at 12 noon on the final day of your reservation. Possible exceptions to the above times will be noted on the booking confirmation/driving instructions.

DRIVING INSTRUCTIONS

Instructions on how to drive to the key handover location or cottage were sent to you with the invoice. We recommend that you follow our driving instructions because a navigator cannot always direct you to the correct place on the basis of the address.

WHAT'S INCLUDED IN THE PRICE?

The cottages contain normal furniture items as well as kitchenware for cooking and dining. Firewood is also covered by the cottage rent unless the cottage description mentions otherwise. Use of a row boat is included in the price of cottages by the water unless the description mentions otherwise.

WHAT SHOULD YOU BRING?

The cottages have mattresses, blankets and pillows. Please bring bedsheets, pillowcases and towels. Most cottages offer the option of renting bed linen and towels; the prices of such packages (incl. bedsheets, pillowcase, bath and hand towel) begin at €10/person. We recommend that you rent bed linen and towels in advance through Lomarengas, as the service may not be available if you request it only after arrival.

Dish washing detergents, basic spices and herbs as well as WC and kitchen rolls are not included in the rental price.

DEPARTURE CLEANING

Departure cleaning is not included in the price unless the destination description states otherwise. We recommend that you order a departure cleaning service so that you can enjoy your holiday to the very end. Make an order in advance via Lomarengas (prices start at €45) or make arrangements with the owner/custodian on arrival. If departure cleaning is covered by the price or you book it as an additional service, all you need to do is wash the dishes and return them to their original place, take the garbage to the waste bin, and take any empty bottles and cans away with you. Furniture should also be returned to its original place.

You can also perform the departure cleaning yourself. It must include the washing and return of dishes to their original place, garbage

removed to the waste disposal point, removal of empty bottles and cans, and putting furniture back to its original place. Food should be taken away or to the waste disposal point. Carpets and floors should be vacuum cleaned, the floors wiped with a damp mop, tables and surfaces wiped with a damp rag, bedclothes aired outdoors, the sauna and WC cleaned. The yard area and barbecue location must be left in a tidy condition. The departure cleaning should be performed in its entirety on the day of departure.

THE COTTAGE OWNER OR CARETAKER WILL ALWAYS HELP YOU

The owner or caretaker will provide assistance on site should you have questions regarding the cottage. Please do not hesitate to contact the owner/caretaker if you discover deficiencies or shortcomings at the cottage. Don't let a shortcoming, which could easily be corrected, ruin your holiday.

If a problem arises, you can also contact the Lomarengas office, tel. +358 306 502 502, or the on-call number +358 400 425 739 at the times mentioned in the booking confirmation.

WE WELCOME YOU TO A SUCCESSFUL COTTAGE HOLIDAY!

Lomarengas

50 years of cottage holidays in Finland.

CONTACT US

Lomarengas

Helsinki | Sörnäisten rantatie 29, FI-00500 Helsinki, Finland
Visiting address: Vilhonvuorenkatu 12, FI-00500 Helsinki, Finland

Nilsinä | Laitilantie 27 A 5, FI-73300 Nilsinä, Finland

Kuusamo | Kirkkotie 23, FI-93600 Kuusamo, Finland

Sotkamo | Kainuuntie 28, FI-88600 Sotkamo, Finland

Tel. +358 (0) 306 502 502 | Fax +358 (0) 306 502 500

sales@lomarengas.fi

Wild Nordic

Joulupukin Pajakylä, Joulumaantie 10,

FI-96930 Napapiiri, Rovaniemi, Finland

Tel. +358 500 599599

sales@villipohjola.fi

Yllas Travel

Luontokeskus Kellokas

Tunturintie 54, FI-95970 Äkäslompolo, Finland

Tel. +358 (0) 306 502 502

yllaksen.matkailu@yllas.fi